



Bharat Heavy Electricals Limited

(High Pressure Boiler Plant)

Tiruchirappalli – 620014, TAMIL NADU, INDIA

CAPITAL EQUIPMENT/ MATERIALS MANAGEMENT

An ISO 9001
Company

ENQUIRY	Phone: +91 431 257 70 49 Fax : +91 431 252 07 19 Email : csguna@bheltry.co.in Web : www.bhel.com
NOTICE INVITING TENDER	

TWO PART BID	Enquiry Number:	Enquiry Date:	Due date for submission of quotation:
Tender to be submitted in two parts.	2620900220	07.10.2009	07.11.2009

You are requested to quote the Enquiry number date and due date in all your correspondence. This is only a request for quotation and not an order.
Please note that under any circumstances both **delayed offer** and **late offers** will not be considered. Hence vendors are requested to ensure that the offer is reaching physically our office before 14.00 hrs on the Date of tender opening.

Item	Description	Quantity
10	CNC Horizontal Boring Machine – 900 mm as per the technical specification, general guidelines instructions & commercial conditions applicable (to be downloaded from web site www.bhel.com or http://tenders.gov.in)	1 No

Important points to be taken care during submission of offer

- Delivery required 10 months from the date of purchase order.**
- Grace period of 2 months beyond the above delivery period will be considered.**
- Checklist to be filled and enclosed along with the offer failing which, the offer will not be considered for evaluation.**

BHEL's General guidelines / instructions (refer MM/CE/GT/001) including bank guarantee formats and list of consortium banks, commercial terms check-list can be downloaded from BHEL web site <http://www.bhel.com> or from the Government tender website <http://tenders.gov.in> (public sector units > Bharat Heavy Electricals Limited page) under Enquiry reference "2620900220".

Tenders should reach us before 14:00 hours on the due date Tenders will be opened at 14:30 hours on the due date Tenders would be opened in presence of the tenderers who have submitted their offers and who may like to be present	Yours faithfully, For BHARAT HEAVY ELECTRICALS LIMITED Sr.Manager / MM / Capital Equipment
--	--

PART A
HORIZONTAL BORING MACHINE
SECTION – I: QUALIFYING CRITERIA

The BIDDER has to compulsorily meet the following requirements to get qualified for considering the technical offer:

S. No.	REQUIREMENTS	Vendor's Response
1	<p>Only those vendors (OEMs), who have supplied and commissioned at least one HORIZONTAL BORING MACHINE with</p> <p>1. Spindle power of 37 KW or more, 2. Spindle diameter of 130mm or above 3. Horizontal boring machine of Ram type</p> <p>in the past ten years and such machine should be working satisfactorily for a minimum period of one year after commissioning, as on the date of opening of this Tender are eligible to quote.</p> <p><i>(However, if such machine is already supplied to BHEL, then that machine should be working satisfactorily for a minimum period of six months after commissioning, as on the date of opening of this Tender.)</i></p>	
	The vendor should submit following information where similar machine has been supplied for qualification of their offer.	
1.1	Name and postal address of the customer or company where similar machine is installed.	
1.2	Name and designation of the contact person of the customer.	
1.3	Phone, FAX no and email address of the contact person of the customer.	
1.4	Month and Year of commissioning of the machine.	
1.5	Parameters of machine supplied, viz. Spindle power, Spindle diameter and the application for which the machine is supplied.	
1.6	Along with the Technical offer, the Vendor should submit one Performance certificate from the customer for the satisfactory performance of the machine supplied to them. For obtaining the Performance certificate, a suggestive format is provided in SECTION – IV .	
1.7	BHEL reserves the right to verify the information provided by vendor. In case the information provided by vendor is found to be false/ incorrect, the offer shall be rejected.	
2.0	DELIVERY - The bidder shall quote the best possible delivery. However the delivery shall not exceed 10 months with an additional grace period of 2 months. The additional grace period will attract a penalty which is explained in the commercial terms of the enquiry. The delivery period shall be reckoned from date of purchase order to despatch from the vendor works.	

SECTION – I I

The BIDDER / VENDOR is requested to provide the following information:

S. No.	REQUIREMENTS	Vendor's Response
3.0	The BIDDER/VENDOR to furnish Reference List of Customers, with full address, details of contact person, where HORIZONTAL BORING MACHINES have been supplied in the past.	
4.0	Details of HORIZONTAL BORING MACHINES supplied to other BHEL units, if any. (Year of commissioning, Spindle power and Spindle diameter).	
5.0	Details on SERVICE-AFTER-SALES Set-Up in India including the Address of Agents / Service Centers in South India.	
6.0	Any Additional Data to supplement the manufacturing capability of the BIDDER for the subject equipment.	

SECTION – III

The BIDDER to note:

S. No.	PARTICULARS	Vendor's Response
7.0	<p>The BIDDER / VENDOR shall submit the offer in TWO PARTS.</p> <ol style="list-style-type: none"> 1. Technical Offer [with PART A & PART B] and Commercial offer. 2. Price Bid. 	
8.0	<p>The Technical Offer shall contain a comparative statement of Technical Specifications demanded by BHEL and Offer Details submitted by the Bidder, against each clause.</p> <p>A just 'CONFIRMED' or 'COMPLIED' or 'YES' or 'NO-DEVIATION' or similar words in the technical comparative statement may lead to disqualification of the Technical Offer.</p>	
9.0	<p>The Technical Offer shall be supported by product Catalogues & Data Sheets and also technical details of Bought-Out-Items with copies of Product Catalogue to the extent possible.</p>	
10.0	<p>The Commercial Offer (given with the Technical Offer) shall contain the Scope of Supply and the Un-Priced Part of the Price-Bid, for confirmation.</p>	

SECTION – IV

The performance certificate should be produced **on Customer's Letter Head.**

PERFORMANCE CERTIFICATE

1. Supplier of the machine		
2. Make & Model of the M/C		
3. Month & Year of Commissioning		
4. Application for which M/C is used		
5	a) Spindle Power (cont. rating) b) Spindle diameter c) Ram dimension d) Spindle Taper	
6. Performance of the Equipment (Tick whichever is applicable)		Satisfactory
		Good
		Average
		Not Satisfactory
7. Service after sales		Satisfactory
		Good
		Average
		Not Satisfactory
Date:		Signature & Seal of the Authority Issuing the Performance Certificate

CABS-3-17N CNC Horizontal Boring Machine

PART-B TECHNICAL SPECIFICATION FOR CNC HORIZONTAL BORING MACHINE			
SCOPE: SUPPLY, ERECTION & COMMISSIONING OF CNC HORIZONTAL BORING MACHINE COMPLYING WITH SPECIFICATION AS DETAILED BELOW:			
SNO	DESCRIPTION FOR BHEL REQUIREMENT	SPECIFIED / TO BE CONFIRMED BY	REMARKS
1.0	PURPOSE & WORKPIECE MATERIAL		
1.1	Purpose: (Operations/Jobs involved) Through boring of T pieces annexure-2	Vendor to note	
1.2	Work Piece Material: The work pieces are forged and ends gas cut. The Inner diameter is irregular as shown in annexure-3	Vendor to note	
1.3	The machine to be designed to suit the machining operation on work piece as per clause 1.1 and 1.2 and cutting parameters as per clause 6.2	Vendor to confirm	
2.0	SPECIFICATION:		
2.1	MACHINE CONFIGURATION: The machine shall be a 5 axis CNC (X,Y,Z,W & B-axes) controlled Horizontal Boring machine with fixed column.		
2.2	HEAD STOCK		
2.2.1	Boring spindle diameter- Preferred 160mm.	Vendor to specify	
2.2.2	Ram Cross section (LxB)	Vendor to specify	
2.2.3	Spindle drive power (AC Continuous Rating - S1)-min 37KW	Vendor to specify	
2.2.4	Spindle speed (Infinitely variable)-Suitable for the cutting parameters as per clause 6.2	Vendor to specify	
2.2.5	Max torque on the boring spindle (Nm) -min 2800	Vendor to specify	
2.2.6	Spindle taper	ISO 50	
2.2.7	Torque-Power-Speed characteristics of the spindle system	Vendor to specify	

CABS-3-17N CNC Horizontal Boring Machine

SNO	DESCRIPTION FOR BHEL REQUIREMENT	SPECIFIED / TO BE CONFIRMED BY	REMARKS
2.2.8	Forward and reverse rotation of spindle motor with suitable braking mechanism. (Complete details with drawings, explanations to be submitted along with the offer.)	Vendor to confirm with details	
2.3	COLUMN:		
2.3.1	Column should be sturdy and fixed to take heavy load	Vendor to confirm with details	
2.4	HEADSTOCK TRAVERSE ON COLUMN:		
2.4.1	Headstock vertical travel (Y-Axis)	1500 mm	
2.4.2	Y-axis feed rate (Infinitely variable)	0.5-2500 mm/min	
2.4.3	Y-axis rapid traverse rate	2500 mm/min	
2.4.4	Axis Resolution	0.01 mm	
2.5	RAM/ SPINDLE TRAVERSE:		
2.5.1	Boring spindle axial travel (W-Axis)	700mm (min)	
2.5.2	Ram axial travel (Z-Axis)	800 mm(min)	
2.5.3	Ram + Spindle Travel	1500mm (min)	
2.5.4	Lowest spindle position from table top	150 mm	
2.5.5	Boring Spindle axis feed rate (Infinitely variable)	0.5-2500 mm/min	
2.5.6	Boring Spindle axis rapid traverse rate	2500 mm/min	
2.5.7	Axis Resolution	0.01 mm	
2.5.8	Ram axis feed rate (Infinitely variable)	0.5-2500 mm/min	
2.5.9	Ram axis rapid traverse rate	2500 mm/min	
2.5.10	Axis Resolution	0.01 mm	
2.5.11	Ram Axes should be independently programmable with Independent Drives and Feed back system.	Vendor to Confirm	
2.6	FEED AND DRIVE SYSTEM:		
2.6.1	Feed drives/ motors for X,Y,Z & W axes [AC servo motors] shall be digital type of either Siemens or Fanuc make (Details of model, make, type etc. to be submitted)	Vendor to Confirm	
2.6.2	Maximum feed force for all axes	Vendor to specify	
2.6.3	Feed back system for X, Y, Z & W axes: Heidenhain linear scales / Rotary Encoder.	Vendor to specify	

CABS-3-17N CNC Horizontal Boring Machine

SNO	DESCRIPTION FOR BHEL REQUIREMENT	SPECIFIED / TO BE CONFIRMED BY	REMARKS
2.6.4	Cleaning of linear scales(if required)	Vendor to specify	
2.6.5	Type of power transmission: Backlash free re-circulating ball screw with Pre-loaded double nut for all axes. (Complete description of the aforesaid including diameter of Ball Screw for each axis, to be submitted with the offer)	Vendor to specify	
2.6.6	Mechanism for locking / clamping X, Y & Z axis	Vendor to specify	
2.7	MACHINE GUIDEWAYS:		
2.7.1	Width of bed guideways, X-axis	Vendor to specify	
2.7.2	Width of column guideways, Y-axis	Vendor to specify	
2.7.3	Details of Guide ways for Ram axis and bearing details of Spindle axis are to be submitted with offer.	Vendor to specify	
2.7.4	Guide ways for X-axis, Y-axis & Z-axis. Details to be submitted. Details of lubrication system provided on Spindle axis are also to be submitted with the offer.	Vendor to specify	
2.7.5	Hardness of guideways	Vendor to specify	
2.7.6	Metallc Telescopic Covers of stainless steel material to be provided with wipers for X & Y axes guide ways. Joints of telescopic covers should be so sealed to avoid mixing of coolant & lubrication oil is to be provided. The telescopic cover for X-axis should be with a slant towards chip conveyor and should be of Walk on Type.	Vendor to confirm	
2.8	ROTARY TABLE :		
2.8.1	Table size (LxB)	Vendor to specify	
2.8.2	Maximum load carrying capacity (Tons)	5 T	
2.8.3	Eccentric Loading permissible	Vendor to specify	
2.8.4	Table rotation (B-axis)-Motorised	360°	
2.8.5	Table rotation (B-axis)- Resolution	Vendor to specify	
2.8.6	Table indexing positions - with locking at	4x90°	
2.8.7	Size of T-slots	For M24 studs	
2.8.8	T-slots pitch (as per DIN standard)	Vendor to specify	
2.8.9	Minimum distance between ram face and table face.	Vendor to specify	

CABS-3-17N CNC Horizontal Boring Machine

SNO	DESCRIPTION FOR BHEL REQUIREMENT	SPECIFIED / TO BE CONFIRMED BY	REMARKS
2.8.10	Loading chart of the table to be submitted.	Vendor to specify	
2.8.11	Mechanism for locking/ clamping of Table axes	Vendor to provide details	
2.8.12	Spindle should reach extreme end of rotary table	Vendor to Confirm	
2.8.13	Guideways for Table Rotation	Vendor to Specify	
2.8.14	Table rotation motor capacity	Vendor to specify	
2.8.15	4 x 90 deg Precision Positioning (Details to be submitted.)	Vendor to specify	
2.8.16	Table cross travel (X axis)-min 1000mm	Vendor to specify	
2.8.17	X-axis feed rate (Infinitely variable)	0.5-2500 mm/min	
2.8.18	X-axis rapid traverse rate	2500 mm/min	
2.8.19	Axis Resolution	0.01 mm	
2.9	CONSTRUCTION:		
2.9.1	Details of material, hardness & constructional details, including explanatory drawings, of various components/assemblies like Column, bed, head stock, ram, spindle, table, guide ways, etc. of the machine.	Vendor to furnish	
2.9.2	Automatic deflection compensation for ram and column effective at any extension of the ram plus spindle is to be provided taking into consideration weight of all possible cutters/ attachments offered. Details of the offered system should be submitted with offer.	Vendor to furnish	
2.9.3	Head Stock Counterbalancing System. (Details of the offered system to be submitted)	Vendor to furnish	
2.10	OPERATION AND CONTROL SYSTEM:		
2.10.1	OPERATOR'S PANEL:		

CABS-3-17N CNC Horizontal Boring Machine

SNO	DESCRIPTION FOR BHEL REQUIREMENT	SPECIFIED / TO BE CONFIRMED BY	REMARKS
2.10.1.1	Swiveling type operator's panel having complete CNC and machine control system with CRT of required configuration shall be provided on the operators platform. All switches on the Operator's panel including that for table rotation should be within reach of operator of height 5' 6" for convenient, efficient & safe operation. All displays/indications should also be conveniently placed accordingly. Layout showing complete details of the panel should be submitted.	Vendor to furnish	
2.10.1.2	An auxiliary pendant, which can be taken to the table for job setting and similar other purposes, should be provided.	Vendor to furnish	
2.10.2 CNC SYSTEM & FEATURES :			
2.10.2.1	Make : Siemens/Fanuc	Vendor to specify	
2.10.2.2	Type : PC based latest version	Vendor to confirm	
2.10.2.3	Latest version, as available at the time of ordering, should be supplied.	Vendor to specify	
2.10.2.4	Details of Standard features.	Vendor to specify	
2.10.2.5	Details of optional features.	Vendor to specify	
2.10.2.6	The system should have full alphanumeric keyboard, TFT colour display(preferably 15"), additional draw-out type QWERTY Key Board and mouse in suitable enclosure, two numbers RS232C serial interfaces, parallel interface for printer, network ready with LAN, electronic hand wheels for all axes, CD/DVD drive unit for data input/output, hard disk of not less than 80 GB, graphic simulation and preinstalled system software & other required softwares etc.Dry run & Simulation to be included.	Vendor to specify	
2.10.2.7	Provision for automatic safe shut down of CNC Control in case of Power Failure	Vendor to specify	
2.10.3 MANUAL CONTROL :			
	Complete manual control of machine with required switches / keys should be provided on operator's panel for selection of required axis, axis direction, cutting feed, spindle rpm, Direction of Spindle Rotation, i.e. CW/ CCW, cutting feed and spindle rpm on/off, display of axis position values etc, for manual operation without using CNC program or MDI mode. Diagram/ Sketches for switches/ keys provided on operators pendant to be submitted.	Vendor to furnish	

CABS-3-17N CNC Horizontal Boring Machine

SNO	DESCRIPTION FOR BHEL REQUIREMENT	SPECIFIED / TO BE CONFIRMED BY	REMARKS
2.10.4	HAND HELD UNIT:		
2.10.4.1	Hand held unit for axis selection, and movement with pulse generator & display is to be offered. This is required for job setting. Make, model no. and literature of the offered hand held unit shall be furnished.	Vendor to Confirm	
2.10.5	UPS FOR CNC SYSTEM:		
2.10.5.1	UPS of 30 minutes backup for CNC system with inbuilt cooling and charge status display (Battery charging /discharging time should be specified by vendor)	Vendor to furnish	
2.11	MACHINE LIGHTS:		
2.11.1	Machine Lights for sufficient illumination of complete working area on both sides of operator's platform should be provided for clear visibility.	Vendor to specify	
2.11.2	A magnetic base portable spot light with sufficiently long cable should also be provided.	Vendor to specify	
2.11.3	Any lights required in the foundation/ pit area shall also be foreseen and supplied by the vendor.	Vendor to specify	
2.11.4	All light fittings, consumables, adapters/receptacles should have compatibility with Indian equivalents	Vendor to specify	
2.11.5	Flashing / rotary type End of Cutting and Program Stop Light.	Vendor to Confirm	
2.12	AIR CONDITIONERS:		
2.12.1	Air Conditioners with Dehumidifiers of suitable / sufficient capacity to be provided for all Electrical / Electronic Panels / Cabinets including Operator's Panel considering specified ambient conditions. Detailed specifications of the same are to be submitted. Make: Rittal / Warner & Finley or any other reputed make acceptable to BHEL. Detailed specifications to be submitted.	Vendor to specify	
2.13	HYDRAULIC SYSTEM :		
2.13.1	The System should be centralised. Hydraulic Tank shall preferably be located at floor level. Hydraulic power pack to have minimum number of pipes/pipe joints and usage of manifolds/stacked valves construction preferred.	Vendor to specify	

CABS-3-17N CNC Horizontal Boring Machine

SNO	DESCRIPTION FOR BHEL REQUIREMENT	SPECIFIED / TO BE CONFIRMED BY	REMARKS
2.13.2	Latest version of pump,valves,accessories etc. preferably Make Rexroth / Vickers should be used.Seals used shall be Merkel/Freudenberg/ Parker/Bushak+Shamban/Hunger/Smrit make. (Details to be submitted)	Vendor to specify	
2.13.3	Power pack should be energy efficient (Hi-low pump system,proper unloading during idling,etc.)Suitable standby pump unit,filter unit etc. shall be provided for critical areas.The pumps should not be kept immersed/inside the tank.	Vendor to Confirm	
2.13.4	All the pipe/hose fittings shall be of standard weld nipple with o-ring seating type (DIN 3865) and no ferrule joints are to be proposed in the hydraulic system.All threaded connections shall be of Metric size.	Vendor to Confirm	
2.13.5	Pressure measuring minimess check points(preferably with 1/4 " BSP end) to be provided,wherever required for quick pressure measuring/setting while troubleshooting.One set of handheld minimess pressure gauge with 1-1.5 m length hose to be supplied.	Vendor to specify	
2.13.6	The power pack should be tropicalised for Indian conditions-for 40 deg C ambient temperature. Refrigerated type cooling system of sufficient capacity to maintain complete Hydraulic System at a temperature not exceeding 50 deg C irrespective of the ambient conditions. BHEL prefers to have direct cooling of oil in the chiller rather than indirect water cooling type. Complete details should be submitted with the offer.	Vendor to specify	
2.13.7	Suitable vibro mounts,compensators,delivery hose between pump and valve block,polypropylene pipe & hose clamps etc are to be provided to minimise the vibration.	Vendor to specify	
2.13.8	Oil used shall be ISO Viscosity grade 32/46/68/150 Centi-stokes at 40 deg C.Maximum pressure shall be 310 bar.	Vendor to Confirm	
2.13.9	Control voltage for all the solenoidss of the valves shall be 24 V DC and all solenoid operated DC valves should have manual over ride position and light indicating.	Vendor to specify	

CABS-3-17N CNC Horizontal Boring Machine

SNO	DESCRIPTION FOR BHEL REQUIREMENT	SPECIFIED / TO BE CONFIRMED BY	REMARKS
2.13.10	Sufficient number of Duplex filter units with stand-by for the required level of cleanliness is to be provided with clog indicators and preferably with reusable type of filter elements. The filter unit shall be of Hydac / Parker / Rexroth or equivalent reputed make acceptable to BHEL. (Details to be submitted).	Vendor to specify	
2.13.11	The flexible hoses used in the system shall be of Gates / Aeroquip / Parker or any other reputed make acceptable to BHEL.	Vendor to specify	
2.13.12	Failure indication for oil level, temperature, pressure, filter clogging should be provided	Vendor to Confirm	
2.13.13	All the pipe / hose end fittings shall be of standard weld nipple with O-ring seating type (DIN 3865 or equivalent) - female swivel nut with 240 cone and o-ring and no ferrule joints are to be used in the hydraulic system. All threaded connections shall be of metric sizes	Vendor to Confirm	
2.13.14	It should be possible to replace hydraulic elements like valves, manifolds etc without disturbing the associated pipelines. The positioning of hydraulic elements should allow easy maintenance	Vendor to Confirm	
2.13.15	All hydraulic pipelines, hoses and electrical control cables to be neatly laid out with proper clamps and flexible hose conveyors wherever required.	Vendor to Confirm	
2.13.16	Suitable leakage oil collection metallic tray to be provided wherever required.	Vendor to Confirm	
2.13.17	All the components in the hydraulic power pack shall be provided with identification numbers, as per the hydraulic circuit and should be pasted with metallic identification number plates.	Vendor to Confirm	
2.13.18	The pipelines to be painted with standard colours. The supplier shall provide the hydraulic circuit with bill of materials giving complete purchase specifications for each item.	Vendor to specify	

CABS-3-17N CNC Horizontal Boring Machine

SNO	DESCRIPTION FOR BHEL REQUIREMENT	SPECIFIED / TO BE CONFIRMED BY	REMARKS
2.13.19	First filling of all required Oils & Grease etc. Should be supplied by vendor. Grease: Servo gem grade 2 (prefered) Indigenous (Indian) source or Indian equivalent and specifications of oils/greases are also to be provided by the vendor.	Vendor to Confirm	
2.14	Machine lubrication: Automatic centralized lubrication system with timer control and suitable metering cartridges to be supplied.	Vendor to Confirm	
2.15	ELECTRICAL SYSTEM :		
2.15.1	415V + 10% / -10%, 50HZ +/- 1.5 HZ, 3 Phase AC (3 wire system) Power Supply Source will be provided by BHEL at a single point near the machine, as per layout recommended by Vendor. All types of cables, connections, circuit breakers etc. required for connecting BHEL's power supply point to different parts of the machine/control cabinets, shall be the responsibility of vendor. Requirement of grounding/earthing with required material details is to be informed by vendor well in advance so that same could be incorporated during construction of foundation.	Vendor to confirm	
2.15.2	Tropicalisation: All electrical / electronic equipment shall be tropicalized. All control cables should be of copper.	Vendor to confirm	
2.15.3	All electrical & electronic control cabinets & panels should be dust and vermin proof and shall have IP 54 protection.	Vendor to confirm	
2.15.4	All electrical components in the cabinets should be mounted on DIN Rail	Vendor to confirm	
2.15.5	All electrical and electronic panels including operator's panel should be provided with fluorescent lamps for sufficient illumination and power receptacles of 220Volts, 5/15 Amp AC. All adapters/receptacles should have compatibility with Indian equivalents.	Vendor to confirm	
2.15.6	Motors shall conform to IEC Standards	Vendor to confirm	
2.15.7	All cables moving with traversing axes should be installed in Caterpillar/ Drag chain. Additionally, all the cable trays required for laying of cables should be included in the offer.	Vendor to confirm	

CABS-3-17N CNC Horizontal Boring Machine

SNO	DESCRIPTION FOR BHEL REQUIREMENT	SPECIFIED / TO BE CONFIRMED BY	REMARKS
2.15.8	Vendor should ensure the proper earthing for the machine and its peripherals.	Vendor to confirm	
2.15.9	In-cycle hour counter with reset facility is to be included in the offer.	Vendor to confirm	
2.16	SAFETY ARRANGEMENTS:		
	Following safety features in addition to other standard safety features should be provided on the machine:		
	1.Machine should have adequate and reliable safety interlocks / devices to avoid damage to the machine, workpiece and the operator due to the malfunctioning or mistakes. Machine functions should be continuously monitored and alarm / warning indications through lights/ alarm number with messages (on CNC display and panels) should be available.	Vendor to confirm	
	2. A detailed list of all alarms / indications provided on machine should be submitted by the supplier.	Vendor to confirm	
	3. All the pipes, cables etc. on the machine should be well supported and protected.	Vendor to confirm	
	4. All the rotating parts used on machine should be statically & dynamically balanced to avoid undue vibrations.	Vendor to confirm	
	5. Emergency Switches at suitable locations as per International Norms are to be provided.	Vendor to confirm	
	6. Oil & water pipe lines should not run with electrical cable in the same tray / trench.	Vendor to confirm	
	7. Safety Lights at both ends of moving column (preferably Flashing during X-travel).	Vendor to confirm	
	8. All lubricated parts like Bed, guide ways shall have provision for collecting the used Lubrication oil from machine guide ways and preventing them from spilling over on to the ground.	Vendor to confirm	
2.17	ENVIRONMENTAL PERFORMANCE OF THE MACHINE :	Vendor to confirm	
	The Machine shall conform to following factors related to environment :		

CABS-3-17N CNC Horizontal Boring Machine

SNO	DESCRIPTION FOR BHEL REQUIREMENT	SPECIFIED / TO BE CONFIRMED BY	REMARKS
	(a) Maximum noise level shall be 85 dB(A) at normal load condition, 1 M away from the machine with correction factor for back ground noise, if necessary. This will be measured as per international standards like DIN 45635-16. Supplier to demonstrate compliance to noise level, if so required.	Vendor to confirm	
	(b) There shall not be any emissions from the machine except fumes of cutting fluid during machining.	Vendor to confirm	
	(c) There should not be any effluent from the machine. In case there are any effluents from the machine, requisite effluent treatment plant or pollution control device should be built into the machine by the supplier.	Vendor to confirm	
	(d) No hazardous chemicals shall be required to be used in the machine.	Vendor to confirm	
	(e) If any safety / environmental protection enclosure is required it should be built in the machine by the vendor.	Vendor to confirm	
	(f) Paint of the machine should be oil / coolant resistant and should not peel off and mix up with coolant.	Vendor to confirm	
3.0	CHIP CONVEYOR :		
3.1	A chip conveyor to carry both short and curly chips efficiently and effectively to the chip bin to be provided on one end of the machine . Two Chips bins of appropriate size of Indian make, with wheels & handle for movement,should also be supplied	Vendor to specify	
3.2	Type of chip conveyor	Vendor to specify	
3.3	Width of conveyor	Vendor to specify	
3.4	Elevation of chip conveyor for chip bin	Vendor to specify	
3.5	Material of chip conveyor (to be rust resistant)	Vendor to specify	
3.6	Provision for smooth flow of chips to the conveyor.	Vendor to specify	
3.7	Operation of chip conveyor (forward & reverse) through push buttons on operator's panel and at Chip Conveyor	Vendor to confirm	
3.8	Layout showing location of chip conveyor to be submitted.	Vendor to confirm	
4.0	SERVO VOLTAGE STABILIZER:		

CABS-3-17N CNC Horizontal Boring Machine

SNO	DESCRIPTION FOR BHEL REQUIREMENT	SPECIFIED / TO BE CONFIRMED BY	REMARKS
4.1	Indian make Oil / Air Cooled servo Controlled Voltage Stabilizer suitable for complete machine, its drives, controls, PLC etc. with no undesirable Harmonics in the stabiliser output.	Vendor to confirm	
4.2	Make. : NEEL / AEI / SERVO MAX	Vendor to specify	
4.3	Model & Rating	Vendor to specify	
4.4	Spares Package for the Voltage Stabiliser for 2 years working should also be offered with item wise list.	Vendor to specify	
4.5	Catalogue of the Voltage Stabiliser shall be submitted with the offer.	Vendor to furnish	
5.0	ULTRA ISOLATION TRANSFORMER		
5.1	Indian make Ultra Isolation Transformer suitable for complete machine , its drives, controls, PLC etc. shall be supplied	Vendor to confirm	
5.2	Make. : NEEL / AEI / SERVO MAX	Vendor to specify	
5.3	Model and Rating	Vendor to specify	
5.4	Spares Package for the Ultra Isolation Transformer for 2 years working should also be offered.	Vendor to specify	
5.5	Catalogue of the Ultra Isolation Transformer shall be submitted with the offer.	Vendor to furnish	
6.0	TOOLINGS:		
6.1	Complete Description of offered Tooling System	Vendor to specify	
6.2	Tooling suitable for ID Boring of T'ees with cutting parameters Cutting speed: 120-150mm/min Depth of cut:5 - 17 mm Cutting Feed: 0.2-0.8mm/rev	Vendor to furnish	
6.3	2 sets of Boring tools with sufficient qty of adopters etc as recommended by vendor for complete machining of prove out components (at BHEL works) should be offered	Vendor to confirm	
7.0	OPTIONAL ACCESSARIES		
7.1	TELE-DIAGNOSTIC SERVICE :		

CABS-3-17N CNC Horizontal Boring Machine

SNO	DESCRIPTION FOR BHEL REQUIREMENT	SPECIFIED / TO BE CONFIRMED BY	REMARKS
7.1.1	Tele-diagnostic service should be provided through International telephone lines along with required Hardware / Software package for the supplied CNC system for remote diagnosis and correction of the problems in both CNC System and PLC of the machine.COM port for telediagnosics, This should be provided free of charge for the guarantee period. Terms and conditions for the service after guarantee period should be informed by vendor. Subsequently, it should be possible to use other platforms, such as Internet or ISDN, subject to their availability in future.	Vendor to give as optional with separate quote	
7.2	FAULT DIAGNOSTIC SYSTEM:		
7.2.1	Supplier's own diagnostic system with required hardware and software should be supplied and installed on the CNC system. This should include customised auto-diagnostic system with supporting hardware and software which shows detailed cause and remedy for the fault on the display with full video diagnostic help for faults related to mechanical and electrical maintenance. On line ladder/STL display of PLC programme should be possible directly on screen or through laptop.	Vendor to give as optional with separate quote	
7.3	Help guide should be provided to use both diagnostic systems	Vendor to offer	
8.0	LEVELING & ANCHORING SYSTEM		
8.1	Complete anchoring system including foundation bolts, anchoring materials, fixators, leveling shoes etc shall be supplied for the Machine, Rotary Table, Floor Plates etc.	Vendor to offer	
9.0	TOOLS FOR ERECTION, OPERATION & MAINTENANCE :		
9.1	Special tools and equipment required for erection of the machine shall be brought by the vendor. Necessary tools like Torque Wrench, Spanners, Keys, grease guns etc.for operation and maintenance of the machine should be supplied. List of such tools should be submitted with offer	Vendor to offer	
9.2	Test mandrel for checking spindle run-out & alignment should be supplied	Vendor to offer	
10.0	SPARES:		

CABS-3-17N CNC Horizontal Boring Machine

SNO	DESCRIPTION FOR BHEL REQUIREMENT	SPECIFIED / TO BE CONFIRMED BY	REMARKS
10.1	Itemised breakup of mechanical, hydraulic, electrical and electronic spares used on the machine in sufficient quantity as per recommendation of Vendor for 2 years of trouble free operation on three shifts continuous running basis should be offered by vendor. The list to include following, in addition to other recommended spares: (Unit Price of each item of spare should be offered)	Vendor to offer	
	a) Mechanical & Hydraulic Spares: All types of pumps, All types of Valves, All types of pressure switches / transducers, All types of filters, All types of seals	Vendor to offer	
	b) Electrical /Electronic / CNC Spares: All types of Relays, Contactors, Proximity Switches, Push Buttons, Indicating Lamps, Semiconductor Fuses, Special Fuses, Circuit Breakers, Main Power Switch, Encoders, Scanning Heads for Linear Scales, MMC module, NCU module, Operator's panel with Display Unit, I/O Cards for PLC, Servo Motors for Feed Drives, Power Module & Control Cards for Main Drive as well as Feed Drives etc.	Vendor to offer	
10.2	All types of spares for total machine and accessories should be available for atleast ten years after supply of the machine. If machine or control is likely to become obsolete in this period, the vendor should inform BHEL sufficiently in	Vendor to offer	
10.3	Recommended set of spares for all attachments are to be offered with details.	Vendor to offer	
10.4	Vendor to confirm that complete list of spares for machine and accessories, along with specification / type / model, and name & address of the spare supplier shall be furnished along with documentation to be supplied with the machine	Vendor to offer	
10.5	Spares listed in Annexure – 1 shall be offered.	Vendor to offer	
10.0	DOCUMENTATION :		
10.1.0	Set of Documents to be submitted along with the Offer for technical evaluation:		
10.1.1	General Lay-out of the machine with major and critical dimensions in line with the specification	Vendor to furnish	
10.1.2	General Assembly drawing of the machine with bill of materials and critical dimensions	Vendor to furnish	

CABS-3-17N CNC Horizontal Boring Machine

SNO	DESCRIPTION FOR BHEL REQUIREMENT	SPECIFIED / TO BE CONFIRMED BY	REMARKS
10.1.3	Sub-assembly drawings with bill of materials and critical dimensions for all the major sub-assemblies in the machine.	Vendor to furnish	
10.1.4	List of bought out items with make and specification along with catalogues: Motors, Gear boxes, Controllers, Drives, Cylinders, Seals, CNC system, PLC, etc.	Vendor to furnish	
10.1.5	Hydraulic / Pneumatic Circuit with Bill of Materials giving specification and make of components used.	Vendor to furnish	
10.1.6	Lubrication Circuit with Bill of Materials giving specification and make of components used.	Vendor to furnish	
10.1.7	Electrical Circuit with Bill of Materials giving specification and make of components used.	Vendor to furnish	
10.1.8	Video images on CD /Hard copy of literature with photographs & drawings explaining the technical features.	Vendor to furnish	
10.2.0	Set of Documents to be submitted after placement of order for approval / verification before manufacturing:		
10.2.1	General Lay-out of the machine with major and critical dimensions in line with the specification	Vendor to confirm	
10.2.2	General Assembly drawing of the machine with bill of materials and critical dimensions	Vendor to confirm	
10.2.3	Sub-assembly drawings with bill of materials and critical dimensions for all the major sub-assemblies in the machine.	Vendor to confirm	
10.2.4	Hydraulic / Pneumatic Circuit with Bill of Materials giving specification and make of components used.	Vendor to confirm	
10.2.5	Lubrication Circuit with Bill of Materials giving specification and make of components used.	Vendor to confirm	
10.2.6	Electrical Circuit with Bill of Materials giving specification and make of components used.	Vendor to confirm	
10.2.7	Quality plan	Vendor to confirm	
10.3.0	Set of Documents to be submitted along with machine:		

CABS-3-17N CNC Horizontal Boring Machine

SNO	DESCRIPTION FOR BHEL REQUIREMENT	SPECIFIED / TO BE CONFIRMED BY	REMARKS
10.3.1	Three sets of following documents as Hard copies and 1 set of all documents including bought out item catalogues – soft copy in CD in English Language should be supplied along with the machine.	Vendor to confirm	
10.3.2	One set of complete documents as Hard copy and complete documents in CD / Pen drive to be submitted during inspection at supplier's works for verification. This forms part of acceptance criteria at supplier's works.	Vendor to confirm	
10.3.3	Operating Manuals of Machine & CNC system	Vendor to confirm	
10.3.4	Programming Manuals for the machine & CNC system.	Vendor to confirm	
10.3.5	Detailed Maintenance manual of machine with all drawings of machine assemblies/sub-assemblies/parts including Electrical /PCB circuit diagrams/ Pneumatic/ Hydraulic Circuit Diagrams. All Assembly/ Sub Assembly Drawings shall be supplied with the part list / Bill of Materials giving complete specification and make of components.	Vendor to confirm	
10.3.6	Hydraulic / Pneumatic Circuit with Bill of Materials giving specification and make of components used. Function diagram of the Hydraulic / Pneumatic system to be provided with the circuit.	Vendor to confirm	
10.3.7	Lubrication Circuit with Bill of Materials giving specification and make of components used.	Vendor to confirm	
10.3.8	Electrical Circuit with Bill of Materials giving specification and make of components used.	Vendor to confirm	
10.3.9	Maintenance, Interface & Commissioning Manuals for for CNC system, spindle & feed drives.	Vendor to confirm	
10.3.10	Manufacturing drawings for all wearing components like bushes, pulleys, gears, clutch plates, etc.	Vendor to confirm	
10.3.11	Manufacturing drawings for all supplied tool holders, cutting tools, adapters, sleeves, fixtures etc.	Vendor to confirm	
10.3.12	Catalogues, O&M Manuals of all bought out items including drawings, wherever applicable highlighting the specific model used in the supplied	Vendor to confirm	
10.3.13	Detailed specification of all rubber items, hoses, fittings, etc. List of bearings, belts used to be provided.	Vendor to confirm	

CABS-3-17N CNC Horizontal Boring Machine

SNO	DESCRIPTION FOR BHEL REQUIREMENT	SPECIFIED / TO BE CONFIRMED BY	REMARKS
10.3.14	Operating Manuals, Maintenance Manuals & Catalogues for all supplied Accessories including Voltage stabilizer, Isolation transformer, etc.	Vendor to confirm	
10.3.15	Complete Master List of parts used in the equipment.	Vendor to confirm	
10.3.16	Complete list of spares for equipments and accessories, along with item part no / specification / type / model, and name & address of the spare supplier shall be furnished.	Vendor to confirm	
10.3.17	PLC program printouts with comments in English.	Vendor to confirm	
10.3.18	PLC program on CD, NC data & PLC data on CD	Vendor to confirm	
10.3.19	Complete back up of hard disk on CD and clear written Instructions (3 copies) to take back up and reloading of a new hard disk.	Vendor to confirm	
11.0	TRAINING:		
11.1	The Vendor shall train Three BHEL's Engineers in Operation and Maintenance (Mechanical, Electrical/ Electronics and CNC System) of the Machine at Vendor's works for a period of 5 working days.	Vendor to confirm	
11.2	The Vendor shall impart training to BHEL's Machine Operators and Maintenance crew in Operation and Maintenance during commissioning of the Machine at BHEL works for 10 working days	Vendor to confirm	
11.3	Airfare, boarding & lodging for the trainees shall be borne by BHEL.	Vendor to confirm	
11.4	Competent, English speaking experts shall be arranged by the vendor during training for satisfactory & effective training of BHEL personnel	Vendor to confirm	
11.5	Vendor to quote for training on per man per day basis for training at vendor's work	Vendor to quote	
12.0	FOUNDATION:		

CABS-3-17N CNC Horizontal Boring Machine

SNO	DESCRIPTION FOR BHEL REQUIREMENT	SPECIFIED / TO BE CONFIRMED BY	REMARKS
12.1	Vendor shall submit the preliminary layout drawing for getting BHEL's approval within one month from the date of Letter of Intent (LOI)/ P.O. , whichever is earlier. Soil condition data will be furnished by BHEL alongwith the approval. Complete Foundation Design including details, like Static/ Dynamic load details etc. and final Layout Drawings shall be submitted by the supplier within three months after getting BHEL's approval. The Layout should consist of all requirements pertaining to complete machine and all accessories, including space requirement for Voltage Stabiliser, Isolation Transformer, , Chip Bin & any other accessory. BHEL shall construct complete foundation for the machine under supervision of supplier and at supplier's responsibility. Vendor should arrange equipment required for the testing of foundation, if required by the vendor. The vendor shall also indicate detailed specifications of grouting compound and grouting procedureetc. for foundation bolts of the machine.	Vendor to confirm	
13.0	ERECTION & COMMISSIONING		
13.1	Supplier to take full responsibility for carrying out the erection, start up, testing of machine, it's control system & all types of other supplied equipment, machining of test pieces etc. Service requirement like power, air & water shall be provided by BHEL at only one point to be indicated by supplier in their foundation/layout drawings. Other requirements like crane and helping personnel shall also be provided by BHEL. Details of these requirements should be informed by vendor in advance.	vendor to confirm	
13.2	Erection & Commissioning of Voltage stabilizer, Isolation Transformer & Air Compressor shall also be responsibility of the vendor.	Vendor to confirm	
13.3	Successful proving of BHEL components by the supplier shall be considered as part of commissioning. All tests, as mentioned at clause 17 (Machine Acceptance) shall form part of the commissioning activity.	Vendor to confirm	
13.4	Tools, Tackles, Test Mandrels, instruments and other necessary equipment including Laser equipment required to carry out all above activities should be brought by the supplier.	Vendor to confirm	

CABS-3-17N CNC Horizontal Boring Machine

SNO	DESCRIPTION FOR BHEL REQUIREMENT	SPECIFIED / TO BE CONFIRMED BY	REMARKS
13.5	Necessary tools like Torque Wrench, Spanners, Keys, grease guns etc. for operation and maintenance of the machine should be supplied. List of such tools should be submitted with offer	Vendor to confirm	
13.6	Special equipments, like test mandrel, straight edge, dial indicators with magnmetic stands, etc. for checking run-out/taper & alignment should be supplied along with the machine.	Vendor to confirm	
13.7	Commissioning spares, required for commissioning of the machine within stipulated time, shall be brought by the supplier on returnable basis.	Vendor to confirm	
13.8	All Cover Plates required for the machine and its peripherals including pits, if any, shall be supplied and installed by the vendor. The plates should be sourced from India	Vendor to confirm	
13.9	Portion, if any, of the machine, accessories and other supplied items where paint has rubbed off or peeled during transit or erection should be repainted and merged with the original surrounding paint by the vendor. For this purpose, the vendor should supply sufficient quantity of touch-up paint of various colours of paint used.	Vendor to confirm	
13.10	Schedule of Erection and Commissioning shall be submitted with the offer.	Vendor to specify	
13.11	Charges, duration, terms & conditions for E&C should be furnished in detail separately by vendor along with offer.	Vendor to specify	
14.0	ACCURACY TESTS:		
14.1	GEOMETRICAL ACCURACIES :		
14.1.1	Geometrical Accuracy Tests shall be in accordance with ISO 3070 standard or equivalent applicable standard. Detailed Test Charts for the same, clearly showing the accuracies to be achieved on the machine, shall also be submitted with the offer.	Vendor to confirm	
14.1.2	All the above accuracies to be demonstrated to BHEL engineers during pre-acceptance tests at Suppliers works and during Erection & Commissioning at BHEL Works.	Vendor to confirm	
14.2	MACHINE POSITIONING ACCURACIES & REPEATABILITY:		
14.2.1	Positioning Accuracy/Repeatability Tests as per VDI-DGQ/3441	Vendor to confirm	
14.2.2	Positioning Accuracy (Pa per 1000mm) for X,Y,Z,W axes	+/- 0.01 mm	

CABS-3-17N CNC Horizontal Boring Machine

SNO	DESCRIPTION FOR BHEL REQUIREMENT	SPECIFIED / TO BE CONFIRMED BY	REMARKS
14.2.3	Repeatability (Ps per 1000mm) for X,Y,Z,W axes	+/- 0.01 mm	
14.2.4	All the above accuracies to be demonstrated to BHEL engineers during pre-acceptance at Suppliers works and during Erection & Commissioning at BHEL Works	Vendor to confirm	
15.0	AMBIENT CONDITIONS & THERMAL STABILITY :		
15.1	<p>Total machine including CNC system and all supplied items should work trouble free and efficiently under following operating conditions and should give specified accuracies.</p> <p>Power Supply: Voltage: 415 V - 10%, +10% Frequency: 50 Hz +3%, - 3% No. of phases = 3 (No neutral) Ambient Conditions: Temperature = 40 degree celsius Relative Humidity = 95% max. (Vendor to confirm that machine is suitable for above and details of provisions on the machine for the same are to be furnished by Vendor)</p>	Vendor to confirm	
15.2	<p>Weather conditions are tropical, Atmosphere may be dust laden during some part of the year. Machine shall be kept in the normal shop floor condition. Max. temperature variation is up to 25 deg Celsius in 24 hours.(Vendor to confirm that machine is suitable for above and details of provisions on the machine for the same are to be furnished by Vendor)</p>	Vendor to confirm	
15.3	<p>Thermal Stability of the complete machine keeping in view specified Ambient Conditions and accuracy requirements of BHEL components and trouble free operation of the machine should be ensured by vendor. (Vendor to confirm that machine is suitable for above and details of provisions on the machine for the same should be furnished by Vendor)</p>	Vendor to confirm	
15.4	<p>The machine, including attachments and accessories, should be suitable for 24 hrs. continuous operation to its full capacity for 24 hour a day and 7 days a week throughout. Vendor to ensure and confirm the same.</p>	Vendor to confirm	
16.0	PROVEOUT OF BHEL COMPONENTS :		

CABS-3-17N CNC Horizontal Boring Machine

SNO	DESCRIPTION FOR BHEL REQUIREMENT	SPECIFIED / TO BE CONFIRMED BY	REMARKS
16.1	<p>Details of proveout components are given in the Annexure 2 &3 . Complete machining of prove out components shall be done by Vendor at BHEL works to the specified design accuracy and surface finish, using cutting tools and CNC programs to be provided by the vendor to prove the machine after complete erection, tests & test piece machining etc. Material for the proveout components shall be provided by BHEL. Vendor should submit the CNC programs, setting schemes, process sheets, tooling layouts, time studies etc. in advance for the prove out components. Vendor shall be fully responsible for machining of proveout components as per drawing and time estimates provided by him and other requirements specified by BHEL to the full satisfaction of BHEL. Clarifications, if any required by vendor, regarding accuracy requirements of the proveout components, whether specified or not, should be discussed and cleared by vendor during initial technical discussions.</p>	Vendor to confirm and give offer with break up details.	
17.0	MACHINE ACCEPTANCE: (Tests/Activities to be Performed by Vendor)		
17.1	Tests/Activities should be carried out at supplier's works on the machine before dispatch :		
17.1.1	Geometrical Accuracy Tests as per test chart.	Vendor to confirm	
17.1.2	Positioning Accuracy/Repeatability Tests as per VDI-DGQ/3441	Vendor to confirm	
17.1.3	The machine should be tested for continuous running of 48 hrs. If any break down occurs during this test, the test should be repeated for 48 hrs from that time.	Vendor to confirm	
17.1.4	Demonstration of all features of the machine, CNC system and all Accessories.	Vendor to confirm	
17.2	Test to be carried out at BHEL works while commissioning the machine :		
17.2.1	Geometrical Accuracy Tests as per test chart.	Vendor to confirm	
17.2.2	Positioning Accuracy/Repeatability Tests as per VDI-DGQ/3441	Vendor to confirm	
17.2.3	Full load test to demonstrate the maximum power & cutting capacity of the machine.	Vendor to confirm	

CABS-3-17N CNC Horizontal Boring Machine

SNO	DESCRIPTION FOR BHEL REQUIREMENT	SPECIFIED / TO BE CONFIRMED BY	REMARKS
17.2.4	The machine should be tested for continuous running of 48 hrs. If any break down occurs during this test, the test should be repeated for 48 hrs from that time.	Vendor to confirm	
17.2.5	Demonstration of all features of the machine, CNC system & all accessories to the satisfaction of BHEL for their efficient and effective use.	Vendor to confirm	
17.2.6	Demonstration by actual use of all supplied attachments and accessories to their full capacity.	Vendor to confirm	
17.2.8	Proveout machining within the time estimates furnished by vendor.	Vendor to confirm	
17.2.10	Training of BHEL machine operators in operation of complete machine & accessories etc by the supplier's experts / engineers during their stay at BHEL works. Training of CNC programmer, mechanical, electrical and electronics maintenance engineers shall be imparted for a period 10 days.	Vendor to confirm	
18.0	PACKING:		
18.1	Sea worthy & rigid packing for all items of complete machine, CNC System, all Accessories and other supplied items to avoid any damage/loss in transit. When machine is despatched in containers, all small loose items shall be suitably packed in boxes.	Vendor to confirm	
19.0	GUARANTEE :		
19.1	12 months from the date of acceptance of the machine or 18 months from the date of supply whichever is earlier.	Vendor to confirm	
20.0	GENERAL : The vendor should submit the following information:		
20.1	Machine Model	Vendor to specify	
20.2	Total connected load (KVA):	Vendor to specify	
20.3	Floor area required (Length, Width, Height) for complete machine & accessories	Vendor to specify	
20.4	Painting of Machine/ Electrical Panels: RAL 6011 Apple Green (Polyurethane Paint)	Vendor to Confirm	
20.5	Total weight of the machine	Vendor to specify	
20.6	Weight of heaviest part of machine	Vendor to specify	

Annexure- 1 SPARES LIST

I	MECHANICAL SPARES	
1	Set of gaskets and O rings (for the entire machine) – list to be provided with part nos. at the time of drawing approval stage.	1 Set
2	Ball screw for w axis	1 No.
3	Drive belts, Feed belts and Toothed belts (1 Set means – 1 No. in each type available in the entire machine)	1 Set
4	Hydraulic pumps (1 Set means – 1 No. of each type of pump available in the hydraulic system)	1 Set
5	Set of contactors, relays and limit switches (1 Set means – 1 No. in each type available in the entire machine)	1 Set
6	Drive pinion for table rotation	1 No.
7	Hydraulic Valves (1 Set means – 1 No. in each type available in the entire machine hydraulic system)	1 Set
8	Hydraulic Pressure switches (1 Set means – 1 No. in each type available in the entire machine)	1 Set
11	Filter elements (1 Set means – 1 No. in each type available in the entire machine)	2 Sets
12	Hydraulic cylinder Seal kits (1 Set means – complete seal kit including O-rings for each type cylinder available in the entire machine) – list to be provided with part nos. at the time of drawing approval stage.	1 Set
13	Hydraulic hoses (1 Set means – 1 No. in each type)	1 Set

	available in the entire machine)	
14	Lubrication pump	1 No.
15	Lubrication – metering cartridges – 2 Nos. of each type	1 Set
16	Spindle bearings (1 Set means – complete set of bearings available in the spindle assembly)	1 Set
II	ELECTRICAL, ELECTRONIC AND CNC SYSTEM SPARES	
1	Proximity switches with suitable proximity switch cord & Limit switches (1 Set means – 1 No. in each type available in the entire machine)	1 Set
2	Push buttons (1 Set means – 1 No. in each type available in the entire machine)	2 Sets
3	Indicating lamps (1 Set means – 1 No. in each type available in the entire machine)	3 Sets
4	Semiconductor fuses (1 Set means – 1 No. in each type available in the entire machine)	2 Sets
5	Special fuses (1 Set means – 1 No. in each type available in the entire machine)	2 Sets
6	Circuit breakers (1 Set means – 1 No. in each type available in the entire machine)	1 Set
7	Encoders (1 Set means – 1 No. in each type available in the entire machine)	1 Set.
8	CNC System spares (list to be provided by vendor along with offer)	1 Set.
9	Servo motor (Model to be provided by vendor)	1 No.

10	Main spindle drive	1 No.
11	Axis drives (1 Set means – 1 No. in each type available in the entire machine)	1 Set
12	Scanner head for Y- axis linear scale	1 No.

CNC HEADER PIPE/FITTINGS BORING AND EDGE PREPARATION MACHINE

Equal 'T'EES

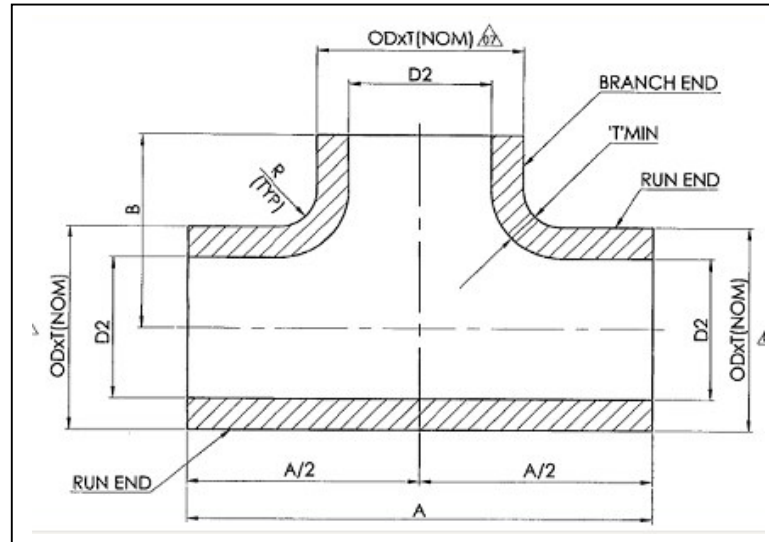

Annexure - 2
Drg No. CABS-1-24-01
BHEL, Tiruchirappalli

Sl. No	OD, mm	T (Nom) Thickness, mm	(A) Length, mm (To which boring to be done)	(B) Length, mm	Available Minimum ID before boring, mm	D2 - ID required after boring in, mm	MATERIALS
1	219.1	18 to 40	340	170	90 to 450	= [OD - 2 x T (Nom)]	SA234 WPB, WPC SA234 WP11, WP12, SA 234 WP22, WP91
2	244.5	43	600	200			
3	273	32 to 46	635	215			
4	323.9	36 to 46	710	255			
5	355.6	45 to 59	760	280			
6	368	28 to 70	760,820	280			
7	406.4	51 to 86	870	305			
8	457.2	25 to 80	1090	338			
9	508	28 to 137	1090,1100	385			
10	558.8	28 to 40	1100	425			

CNC HEADER PIPE/FITTINGS BORING AND EDGE PREPARATION MACHINE

Unequal 'T'ees

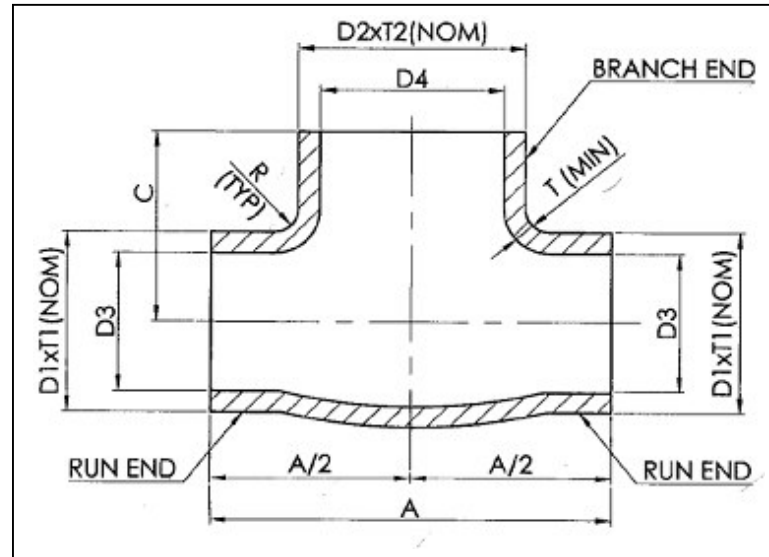

Annexure - 2
Drg No. CABS-1-24-02
BHEL, Tiruchirappalli

Sl.No	D1/D2, mm	T1 & T2 (Nom) Thickness mm	(A) Length, mm (To which boring to be done)	(C) Length, mm	Available Minimum ID Before Boring mm	D3 - ID required after boring on RUN END and D4 - ID required on Branch End, mm	MATERIALS
1	219.1/273	34	990	216	90 TO 450	D3= [D1 - 2 x T1 (Nom)] & D4= [D2 - 2 x T2 (Nom)]	SA234 WPB, WPC SA234 WP11, WP12 SA234 WP22, WP91
2	273/323.9	34, 37	990	254			
3	323.9/368	57, 69	790	280			
4	323.9/406.4	51 to 80	870	310			
5	368/406.4	62	870	310			
6	406.4/508	68 to 86	1100	385			
7	406.4/457.2	68	1090	338			
8	457.2/508	80	1200	381			
9	457.2/558.8	28	1230	415			
10	508/558.8	28	1230	425			

ANNEXURE 3

TYPICAL FORMED FITTINGS - PHOTOS



1. Ø219mm Formed 'T' Fittings



2. Ø219mm Formed 'T' Fittings



3. One end of 'T' fitting - Closer View



4. Ø 273mm 'T' fitting

ANNEXURE 3

TYPICAL FORMED FITTINGS - PHOTOS



5. Ø 219mm 'T' fitting



6. Ø 273mm 'T' fitting



7. Unequal 'T' fitting



8. Run end of Unequal 'T' fitting



9. Branch end of Unequal 'T'



An ISO 9001 Company

Bharat Heavy Electricals Limited
(High Pressure Boiler Plant)
Tiruchirappalli-620014, Tamil Nadu, India
MM/CAPITAL EQUIPMENT/MODERNISATION

Document No.MM/CE/GT/001

GENERAL GUIDELINES & INSTRUCTIONS TO BIDDERS FOR SUBMITTING OFFER

Vendors are requested to read the following points / guidelines / instructions and ensure that the offer is prepared and submitted strictly as per the requirements. Offers with insufficient details would not be considered for evaluation. The following points / guidelines / instructions are part and parcel of the tender and non-compliance will result in rejection of offer.

1.0 QUOTATIONS

Considering the nature of procurement which requires a good amount of technical details, brochures, catalogues etc., to be submitted along with the offer as well as the confidentiality required to be maintained during the offer evaluation process, bidders are requested to submit their offers only through sealed bids. As the part II (the price bid) would not be opened before the technical evaluation is completed, bidders are requested not to submit their bids through email / fax etc.

Bidders shall submit the offer in **TWO INNER ENVELOPES** as indicated below which shall be sealed in one outer envelope.

Envelope I This sealed envelope should contain all the copies of technical bid together with un-priced commercial bid. This envelope should be clearly marked "**Part I - Technical and Un-priced commercial bid**", indicating Enquiry No., Due Date, Address & Reference of the Bidder.

Envelope II This sealed envelope should contain **price details**. This envelope should be clearly marked "**Part II - Price bid**", indicating Enquiry No., Due Date, Address & Reference of the Bidder

Both the envelopes (Part I & II) shall be put in one cover, duly sealed, super scribing as Part I and Part II indicating Enquiry No., Due Date, Address & Reference of the Bidder.

The above tender (envelope containing Part I & II) should reach this office on or before the due date by 14.00 Hrs (IST). Tenders received after 14.00 Hrs (IST) will not be considered for evaluation.

Tender should not be addressed to any Individual's name but only by designation to:

**AGM / MM / CAPITAL EQUIPMENT / MODERNISATION
4th Floor – Building 24,
BHARAT HEAVY ELECTRICALS LIMITED
HIGH PRESSURE BOILER PLANT
TIRUCHIRAPALLI – 620 014
TAMIL NADU, INDIA**

Tenders should be free from **CORRECTION AND ERASURES**, Corrections if any, must be attested. All amounts shall be indicated both in words as well as in figures. Where there is difference between amount quoted in words and figures, amount quoted in words shall prevail.

Tenders should be in **ENGLISH** and accompanied by detailed technical literature, catalogue and detailed dimensional drawings in **ENGLISH** or otherwise, the tenders will not be considered for evaluation.

Tenders will have to be submitted by the Original Equipment Manufacturer only.

2.0	PART I (TECHNICAL & UN-PRICED COMMERCIAL BID)
------------	--

2.1	Technical
------------	------------------

This part shall include / indicate the following:

2.1.1	Tenders should contain complete scope of supply with all technical details, specifications, delivery and other commercial terms and conditions.
2.1.2	Point by point confirmation for the Technical Specification enclosed is to be provided. If there are any deviations, the same should be clearly specified. Tenders received without confirmation to our specification will be rejected.
2.1.3	List of customers to whom same or similar equipment have been supplied along with performance certificates are to be enclosed.
2.1.4	Relevant catalogues to be attached
2.1.5	List of spares parts (with part numbers) for two years operation and maintenance should be attached.
2.1.6	Information on shipping weight and cubage (length, width & height) to be provided.

2.2	Un-Priced Commercial
------------	-----------------------------

This part shall include / indicate the following:

2.2.1	Acceptance of commercial terms and conditions by the bidders (in the check-list enclosed)
2.2.2	Port of shipment / Station of despatch
2.2.3	Terms of payment
2.2.4	CFR price up to Chennai port (for foreign bidders). FOR BHEL, Tiruchy price (for Indian bidders)
2.2.5	Taxes, Service tax & duties including cess applicable.
2.2.6	Delivery Schedule from the date of Purchase Order
2.2.7	Offer validity
2.2.8	Country of origin
2.2.9	Currency in which the price has been indicated.
2.2.10	Percentage of agency commission if any along with a copy of Agency agreement. The CFR prices quoted shall include the agency commission.
2.2.11	A copy of "Un-Priced Part II" i.e., a copy of the Price Bid without the price details to be enclosed.

3.0	OPENING OF TENDERS
------------	---------------------------

The Part I - Technical & Un-priced commercial bid alone would be opened on the Tender opening date.

The Part II – The Part I would be evaluated and bidders qualifying alone will be considered for further processing. BHEL would proceed with Reverse Auction route or Price Bid opening route for finalizing the tender, which would be intimated to the qualified bidders after completion of the techno-commercial evaluation.

BHEL reserves the right to go for a Reverse Auction (RA) instead of Opening the Price Bid submitted, which will be decided after the techno-commercial evaluation. Information and general terms and conditions governing RA are given below.

GENERAL TERMS AND CONDITIONS OF RA

- Against this enquiry for the subject item/system with detailed scope of supply as per enquiry specifications, BHEL may resort to “REVERSE AUCTION PROCEDURE” i.e., ON LINE BIDDING ON INTERNET.
- For the proposed RA, technically and commercially acceptable bidders only shall be eligible to participate.
- In case of RA, BHEL will engage the services of a service provider for conduct of the RA who will provide all necessary training and assistance to the bidders before commencement of on line bidding on internet.
- Business rules governing the RA will be communicated to the bidders through service provider for compliance.
- Vendors have to fax the Compliance form in the prescribed format (provided by Service provider) before start of RA. Without the compliance, the vendor will not be eligible to participate in the event.
- BHEL will provide a sample calculation sheet (in EXCEL format) which would help the bidders to arrive at “Net Cash outflow to BHEL” considering various price / cost elements like Packing & forwarding charges, Taxes and Duties, Freight charges, Insurance, Service Tax for Services and loading factors (for non-compliance to BHEL standard Commercial terms & conditions) etc. for each of the bidders to enable them to arrive at “Net Cash outflow to BHEL” which is the amount the bidder would be bidding during the RA.
- RA will be conducted on scheduled date & time and at the end of event, the lowest bidder value will be known on the network.
- The lowest bidder has to Fax the duly signed “Price Break-up” in prescribed format as provided on case-to-case basis to BHEL through Service provider within 24 hours of Auction without fail.
- Any variation between the on-line bid value and the signed document will be considered as sabotaging the tender process and will invite disqualification of vendor to conduct further business with BHEL, as per the prevailing procedure.

- BHEL reserves the right to negotiate if need be, with the “L1” vendor of the Reverse Auction

4.0	DEFINITIONS & OTHER TERMS
------------	--------------------------------------

Fixed price: Prices quoted by the bidder shall be fixed and not subject to any escalation whatsoever during the period of bid validity and execution of the Purchase Order. A bid submitted with an adjustable price will be treated as non-responsive and rejected. Prices shall be written in words and figures. In the event of difference, the price written in words shall be valid and binding.

Bid currency: Indian bidders should submit the prices only in Indian Rupees. Foreign bidders may submit the bid in their home currency, which should be clearly indicated in the un-priced commercial bid as well as in the price bid.

Taxes and Duties: All Taxes and Duties payable as extra to the quoted price should be specifically stated in offers along with CST & TIN No / Tariff No. etc., failing which BHEL will not be liable for payment of such Taxes and Duties. Our TIN No. 33243560005, TNGST No. 3560005, CST. No. 239383 Dt. 11-06-1991 & BHEL ECC No. AAACB4146PXM012, Assessment circle Tiruverumbur. Our I E Code: 0588138690.

For services rendered by the foreign vendor in India (like Erection & Commission supervision etc.) Income Tax (IT) shall become payable by the Foreign vendor. Hence, Foreign bidders are requested to take care of the IT payment during submission of tender.

Cenvat & VAT credit: (applicable for Indian Bidders only) the quotation must indicate Tariff item number and rate of Excise Duty applicable. The original Excise Duty Gate Pass will be required to be furnished in case Excise Duty is applicable. If the bidder is availing Cenvat credit for his input materials, the effect of proforma credit should be passed on to BHEL.

Packing: The Supplier shall arrange for packing suitably in all respects considering the peculiarity of the material involved for normal safe transport by sea / air / rail / road and suitably protected against effect of tropical salt laden atmosphere in the event of shipment being delayed at ports.

Salient points of HSE (Health Safety & Environment) that are to be considered while submission of offer are:

- Consumption benchmarks related to output shall be provided wherever applicable for key input resources (energy/fuel/chemicals)
- Competency requirements for operation, maintenance and calibration, if any, shall be communicated
- If any hazardous chemicals as per MSIHC (Manufacturing, Storage and import of such Hazardous Chemicals) Rules 1989/94/2000 are used, the MSDS shall be provided along with On site & Off site emergency plan (as applicable)
- The noise level at operator level shall be within 80 dBA
- OH&S (Occupational Health and Safety) control measures for safe working of machine as applicable shall be specified.
- The machine / equipment shall be fitted with guard for rolling and moving parts and shall comply with applicable OH&S legislations and Factories Act 1948
- The supplier shall submit the layout drawing of operating controls, displays etc. Along with operating instructions to enable ergonomics evaluation and approval.
- The recommended list of PPE (Personal Protective Equipment) for the equipment shall be furnished.

- Alarm system (both visual and audible) and Automatic switch off of the equipment shall be provided for any intrusion, overloading, short circuiting or any malfunctioning of the equipment
- Details of all hazardous / harmful substances discharged as by-products / wastes during operations of the machine / equipment, such as fumes, gases, dust particles, aerosols UV/IR (Ultra violet / infra red) radiations etc., shall be furnished along with their concentrations and their TLV, (Threshold Limit Value).
- Appropriate pollution control measures shall be proposed to keep the emissions from the machinery / processes within the prescribed limit as stated in Environment Protection Rules 1986.
- All furnaces, process units, DG sets, paint booths, shot blasting chambers, etc. shall be provided with stack(s) of sufficient height as per guidelines laid down in the Environment Protection Rules 1986.
- Wherever industry specific standards are not available for control of pollutants, general emission standards shall be used.
- Chemicals banned due to their negative impact on the environment shall not be used in the process.
- Fuels with sulphur content less than 0.05% shall be proposed.
- Details regarding nature of waste generated and appropriate disposal practices available shall be provided, along with the operation procedure of the plant / process. Hazardous chemicals and flammable substances shall be transported only through authorized transporters and all safety practices as laid down in applicable legislative requirements such as Central Motor Vehicle Rules, Manufacture, Storage and Import of Hazardous Chemical 1989, etc. shall be followed
- Primary materials used in the equipment shall be specified and they shall be eco-friendly

Force Majeure clause: If at any time during the continuance of the contract the performance in whole or in part by either party of any obligations under the contract is prevented or delayed by reason, of any war, hostilities, acts of the public enemy, civil commotion, sabotage, fires, explosions, epidemics, quarantine, restrictions or acts of GOD (hereinafter referred to as events) and notice of happening of any such events is given by either party to other within twenty one days from the date of occurrence thereof then neither party shall by reason of such events be entitled to terminate the contract. If the performance in whole or part of any obligation under this contract is prevented or delayed by reason of occurrence of such events, then claims for extension of time shall be granted for period considered reasonable by the purchaser subject to prompt notification by the seller to the purchaser the particulars of the events, if required with supporting evidence. Any waiver of time in respect of partial instalment shall not be deemed to be a waiver of time in respect of remaining deliveries.

Agency agreement from foreign suppliers for their Indian agents: Based on Ministry of Finance vide circular dated 31/01/1989 the following are compulsory:

- Registration of Indian agents of a foreign supplier.
- Precise relationship between foreign suppliers and their Indian agents and their mutual interest in the business, should be clearly spelt out.
- Any payment, which the agent receives in India or abroad, from the foreign supplier, whether as a commission or as a general retainer fee, also needs to be brought on record and made explicit so as to ensure compliance to tax laws and to prevent leakage of foreign exchange.
- All services to be rendered by the agent, whether of general nature or in relation to the particular contract, must be clearly stated by the foreign supplier and the Indian agent.

- The amount of agency commission agreed to between the foreign principal and the Indian agent should be specifically disclosed and the agency commission will be paid in Indian Rupees only.

Short shipment / Warrantee replacement: In case of any short-shipment during initially supply, subsequently dispatched by the supplier or any warrantee replacement dispatched during the warrantee period shall be dispatched on “DDP – Delivered Duty Paid BHEL Stores” basis for foreign suppliers and “FOR BHEL Stores” basis for Indian suppliers.

Inspection & Testing: All goods shall be subject to inspection by BHEL or its authorized representatives at supplier’s works or at BHEL Stores. The supplier will not charge for the facilities provided for inspection of goods. In case of machine tools, the machine would be inspected and proved at supplier’s works prior to dispatch. However, final inspection and acceptance of the machine will be carried after installation of the machine BHEL.

5.0	GENERAL
------------	----------------

Tenders will have to be submitted by the Original Equipment Manufacturers only and the offered equipment shall be “New”. Offers for Re-built / Re-conditioned / Used equipments will not be accepted. Incomplete offers will not be considered for evaluation.

Evaluation of offers shall be on “Net Cash Outflow to BHEL basis”.

BHEL reserves its right to allow to the Public Sector Enterprises ordering and price preference facilities as admissible under the existing policy.

BHEL reserves its right to reject a tender due to unsatisfactory past performance in the execution of a contract at any of BHEL projects / Units.

BHEL shall be at liberty to reject or accept any tender, part or in full, at their own discretion and any such action is not liable for any question or claim against BHEL.

The correspondence exchanged against the tender between the bidder and BHEL through email are considered as valid document legally though it is not signed. It is treated as valid confirmations made on behalf of the respective company and very much comes under the legal ambit of the business transaction and hence it is binding on both the parties to the business.

Any transaction / communication pertaining to the tender carried out by the bidder and BHEL round the clock irrespective of the office or business hours of the companies, are valid legally and binding on both the parties. This applies to the extent only in such cases where deadline time for transaction is not specifically declared by either or both the parties to the business.

In case Letter of Intent (LoI) is issued through email, the computer generated time and date of mail shall be construed as the official time and date of release of LoI. In as much as this date is within the last date of validity given by the bidder the LoI is said to have been issued within the validity period and shall be binding on both the parties to the business.

Bidders participating in the tender should declare in their technical bid that whether they have been black-listed / kept on hold for a specified period / given Business holiday for a specified period by any Public sector undertaking or Government departments. The reasons for such action with details and the current status of such hold shall be clearly furnished to

BHEL. If no such details are mentioned in the offer then it will be construed that the subject bidder is not under any such hold. But at a later date if it comes to the notice of BHEL about any such hold under enforcement on the subject bidder, BHEL will have every right to reject the offer of such vendors at any point of time and also under any stage of the finalisation of the subject tender irrespective of the status of the subject bidder in that tender. Such bidders will not be permitted to participate in the further tender proceedings and will be communicated suitably. They will not be also considered for any ongoing enquiries even if participated till the hold is officially lifted and confirmed in writing.

CONTRACT EXECUTION BANK GUARANTEE BOND

This deed of guarantee made this day of 200. by the..... Bank Ltd, (hereinafter referred to as "the Bank") in favour of Bharat Heavy Electricals Limited, Tiruchirappalli having its registered Office at New Delhi with its Unit Office at Tiruchirappalli where as M/s..... having its registered office at (hereafter called the "the Contractor") have entered in to contract with Bharat Heavy Electricals Limited, Tiruchirappalli for the supply of vide Purchase Order No dated

1. We Bank Ltd, do hereby undertake to pay to Bharat Heavy Electricals Limited, Tiruchirappalli an amount not exceeding Rs..... against any loss or damage caused to or suffered or would be caused to or suffered by Bharat Heavy Electricals Limited, Tiruchirappalli by reason of any breach by the said Contractor of any of the terms or conditions contained in the said Purchase Order.

2. We, Bank Ltd, do hereby undertake to pay the amounts due and payable under this guarantee without any demur, merely on a demand from Bharat Heavy Electricals Limited, Tiruchirappalli stating that the amount claimed is due by way of loss or damage caused to or would be caused to or suffered by Bharat Heavy Electricals Limited, Tiruchirappalli by reason of any breach by the said Contractor of any of the terms or conditions contained in the said Purchase Order or by reason of the Contractor's failure to perform the said Purchase Order. Any such demand made on the Bank shall be conclusive as regards the amount due and payable by the Bank under this guarantee. However, our liability under this guarantee shall be restricted to an amount not exceeding Rs.....

3. We, Bank Ltd, further agree to the guarantee herein contained shall remain in full force and effect during the period that would be taken for the performance of the said Purchase Order and that it shall continue to be enforceable till all the dues of Bharat Heavy Electricals Limited, Tiruchirappalli under or by virtue of the said Purchase Order have been fully paid and its claims satisfied or discharged or till Bharat Heavy Electricals Limited, Tiruchirappalli certifies that the terms and conditions of the said Purchase Order have been fully and properly carried out by the said Contractor and accordingly discharges the guarantee. Unless a demand or claim under this guarantee is made on us in writing on or before the we shall be discharged from all liability under this guarantee thereafter.

For the purpose of this clause, any letter making demand on the Bank by Bharat Heavy Electricals Limited, Tiruchirappalli dispatched by Registered Post with Ack. Due or by Telegram or by any Electronic media addressed to the above mentioned address of the Bank shall be deemed to be the claim / demand in writing referred to above irrespective of the fact as to whether and when the said letter reaches the Bank, as also any letter containing the said demand or claim is lodged with the Bank personally.

4. We,.....Bank Ltd, further agree with Bharat Heavy Electricals Limited, Tiruchirappalli that Bharat Heavy Electricals Limited, Tiruchirappalli shall have the fullest liberty without our consent and without affecting in any manner our obligations hereunder to vary any of the terms and conditions of the said Purchase Order or to extend time of performance by the said contractor from time to time or to postpone for any time or from time to time any of the powers exercisable by Bharat Heavy Electricals Limited, Tiruchirappalli against the said Contractor and to forbear or enforce any of the terms and conditions relating to the said Purchase Order and we shall not be relieved from our liability by reason of any

such variation, or extension being granted to the said Contractor or for any forbearance, act or omission on the part of Bharat Heavy Electricals Limited, Tiruchirappalli or any indulgence by Bharat Heavy Electricals Limited, Tiruchirappalli to the said Contractor or by any such matter of thing whatsoever which under the law relating to sureties would but for this provision have effect of so relieving us.

5. Any claim or dispute arising under the terms of this document shall only be enforced or settled in the Courts at Tiruchirappalli.

We, Bank Ltd, lastly undertake not to revoke this guarantee during its currency except with the previous consent of Bharat Heavy Electricals Limited, Tiruchirappalli in writing.

In witness whereof we..... (indicate the name of Bank) have hereunto setout Bank Seal the..... day month 200

The contact details of the Issuing Bank such as Email ID, Phone No. and Fax No. should be indicated in the CEBG. Also please note that the CEBG should be forwarded to us with the covering letter of the issuing Bank with signature and seal.

Please note that issuance of the CEBG without meeting the above requirement will render the document invalid.

PERFORMANCE BANK GUARANTEE BOND

In accordance of M/s. Bharat Heavy Electricals Limited (A Government of India undertaking, a company incorporated under the Companies Act 1956 having its Registered Office at "BHEL House", SIRI Fort, New Delhi 110 049) through its High Pressure Boiler Plant Division located at Tiruverumbur, Tiruchirappalli- 620014 (hereinafter called 'the Company') having entered into a contract withhereinafter called 'the said Supplier and under the terms and conditions of the Purchase Order No..... Dt Between BHEL, Tiruchy and as per the Purchase Order, the Supplier is to furnish a performance Bank guarantee for Rs. for the due performance of the equipment to be supplied under the above referred Purchase Order and for the fulfilment of all the terms and conditions of the Purchase Order, We(indicate the name of the bank) (herein after referred to as the bank) at the request of (Supplier) do here by undertake to pay the Company an amount not exceeding Rs.....against any loss or damage caused to or suffered or would be caused to or suffered by the Company by reason of any breach by the said Supplier of any of the terms and conditions contained in the said Purchase Order.

2. We(indicate the name of the bank with full address), do hereby undertake to pay the amounts due and payable under this guarantee without any demur, merely on a demand from the Company stating that the amount claimed is due by way of loss or damage caused to or would be caused to or suffered by the Company by reason of breach by the said Supplier of any of the terms and conditions contained in the said Purchase Order or by the reason of the Supplier's 'failure to perform' the said Purchase Order. Any such demand made on the Bank shall be conclusive as regards the amount due and payable by the Bank under this guarantee. However, our liability under this guarantee shall be restricted to an amount not exceeding Rs.....

3. We undertake to pay unconditionally to the Company any money so demanded notwithstanding any dispute(s) raised by the Supplier in any suit, or proceedings pending before any Court or Tribunal or Arbitration or before any other authority relating thereto our liability under this present being absolute and unequivocal. The payment under this guarantee would not wait till the disputes have been decided by any Court or Tribunal or in the arbitration proceedings or by any other authority. The payment so made by us under this Bond shall be a valid discharge of liability for payment thereunder and the Supplier shall have no claim against us for making such payment.

4. We.....(indicate the name of Bank), further agree that the guarantee herein contained shall remain in full force and effect during the period that would be taken for the performance of the said Purchase Order and that it shall continue to be enforceable till all the dues of the Company under or by virtue of the said Purchase Order have been fully paid and its claims satisfied or discharged or till Office / Department / Division of the Company certify that the terms and conditions of the said Purchase Order have been fully and properly carried out by the said Supplier and accordingly discharge this guarantee.

5. (i) Unless a demand or claim under this guarantee is made on us in writing on or before the we shall be discharged from all the liability under this guarantee thereafter. But where such claim or demand has been preferred by the Company with the Bank before the expiry of the said date, the claim shall be enforceable notwithstanding the fact that the said enforcement is effected after the said date.

(ii) For the purpose of this clause, any letter making demand on the Bank by BHEL dispatched by Registered Post with Ack. Due or by Telegram or by any Electronic media addressed to the above mentioned address of the Bank shall be deemed to be the claim / demand in writing referred to above irrespective of the fact as to whether and when the said letter reaches the Bank, as also any letter containing the said demand or claim is lodged with the Bank personally.

6. We(indicate the name of Bank), further agree with the Company that the Company shall have the fullest liberty without our consent and without affecting in any manner our obligations hereunder to vary any of the terms and conditions of the said Purchase Order or to extend time of performance by the said Supplier from time to time or to postpone for any time or from time to time any of the powers exercisable by the Company against the said Supplier and to forbear or enforce any of the terms and conditions relating to the said Purchase Order and we shall not be relieved from our liability by any reason of any such variation or extension being granted to the said Supplier or for any forbearance, act or omission on the part of the Company or any indulgence by the Company to the said Supplier or by any such matter or thing whatsoever which under the law relating would, but for this provision, have effect of not so relieving us.

7. This guarantee will not be discharged due to the change in the constitution of the Bank or the Supplier.

8. It shall not be necessary for the Company to proceed against the Supplier before proceeding against the guarantor--Bank and the guarantee herein contained shall be enforceable against them notwithstanding any security, which the Company may have obtained or obtain from the Supplier shall, at the time when proceedings are taken against the guarantor hereunder be outstanding or unrealised.

9. Any claim or dispute arising under the terms of this document shall only be enforced or settled in the Courts at Tiruchirappalli.

10. The guarantor hereby declare that it has power to execute this guarantee and the executants has full powers to do so on its behalf under the proper authorities granted to him/them by the guarantor.

11. We (indicate the name of Bank) lastly undertake not to revoke this guarantee during its currency except with the previous consent of the Company in writing.

In witness whereof we..... (indicate the name of Bank) have hereunto setout Bank Seal the..... day month 200

The contact details of the Issuing Bank such as Email ID, Phone No. And Fax No. Should be indicated in the PBG Also please note that the PBG should be forwarded to us with the covering letter of the issuing Bank with signature and seal.

Please note that issuance of the PBG without meeting the above requirement will render the document invalid.

LIST OF CONSORTIUM BANKS

(as on 21.08.2008)

1. State Bank of India
 2. Canara Bank
 3. Punjab National Bank
 4. Bank of Baroda
 5. Corporation Bank
 6. Syndicate Bank
 7. Oriental Bank of Commerce
 8. Indian Bank
 9. State Bank of Travancore
 10. State Bank of Hyderabad
 11. IDBI Limited
 12. ICICI Bank Limited
 13. HDFC Bank Limited
 14. Kotak Mahindra Bank
 15. The Honking and Shanghai Banking Corporation Limited
 16. Standard Chartered Bank
 17. Citi Bank
 18. Deutsche Bank
 19. ABN Amro Bank
 20. UCO Bank
 21. Central Bank of India
 22. The Federal Bank Limited
-

BHARAT HEAVY ELECTRICALS LIMITED TIRUCHIRAPALLI CAPITAL EQUIPMENT

Document No.MM/CE/CL/LC/IMP/002

ACCEPTANCE OF COMMERCIAL TERMS AND CONDITIONS BY THE VENDORS.

(This should be essentially filled in and sent along with the techno-commercial offer without fail. If this check list is not filled and submitted along with techno-commercial offer (Part I) or if the vendor does not confirm acceptance to the terms and conditions proposed, BHEL reserves the right to reject such offer)

CHECK-LIST FOR FOREIGN VENDORS

Description of the Equipment:	CNC Horizontal Boring Machine – 900mm
BHEL Tender No. & Date:	2620900220 dated 07.10.2009

SI No	Description
1	<p>Price Bid: Price Bid should contain the schedule of price particulars and to be co-related to the technical details provided in Part I. Techno-commercial bid alone without the Price Bid will be rejected. The prices contracted shall be firm till the execution of the contract in full and in all respects.</p> <p>Vendor's confirmation: Accepted.</p>
2	<p>Currency of payment: Foreign vendors to indicate the currency like Euro (€) / US\$ / GBP / JY etc. in the confirmation below. In case the foreign vendor sources some components from India for direct supply to BHEL, the payment for those components shall only be in Indian Rupees</p> <p>Vendor's confirmation:</p>
3	<p>Validity: Validity of the offer should be 120 days from the date of tender opening. Please mention the validity period in the confirmation below. <u>BHEL reserves the right not to consider offers from vendors with validity less than 120 days from the date of tender opening.</u></p> <p>Vendor's confirmation:</p>
4	<p>Release of Purchase Order, submission of CEBG & PBG and terms of Payment:</p> <ul style="list-style-type: none"> ➤ Purchase Orders (separate for supply and service portion) will be released on the successful vendor. ➤ The successful vendor shall have to provide a Contract Execution Bank Guarantee (CEBG) only from any one of the 'Consortium Banks' of BHEL (list enclosed) for 5% of the Purchase Order value in the format enclosed within 30 days from the date of Purchase Order. <u>BHEL reserves the right to cancel Purchase Orders in case the supplier fails to submit the CEBG within 30 days from Purchase Order date.</u> ➤ The payment terms for the supply Purchase Order shall be 80% against shipment and 20% after commissioning of the equipment in BHEL. ➤ An Irrevocable unconfirmed L/C will be opened for 24% of the supply Purchase Order value after receipt of CEBG. ➤ The above L/C would be enhanced to 80% of the supply Purchase Order value 2 months before the shipment date. ➤ The above L/C can be negotiated after shipment against submission of B/L or AWB and such other documents as mentioned in the Purchase Order. The above L/C will be valid for a period extending 21 days beyond the shipment date for negotiation of documents. ➤ The second Irrevocable unconfirmed L/C will be opened for a value equal to

	<p>20% of the supply Purchase Order value plus 100% of the service Purchase Order value, 15 days prior to the arrival of the foreign technicians in BHEL. The validity of the L/C would be sufficient to cover the service period required for completion of the commissioning plus 21 days as negotiation period. This L/C can be negotiated after commissioning of the equipment in BHEL against commissioning certificate jointly signed by BHEL and the vendor and submission of Performance Bank Guarantee (PBG) only from any one of the 'Consortium Banks' of BHEL (list enclosed) for 10% of the Purchase Order value in the format enclosed.</p> <p><u>Offers from vendors not accepting to receive at least 20% payment of the supply Purchase Order value after commissioning of the equipment will be rejected.</u></p>
	<p>Vendor's confirmation: Accepted to BHEL's above terms.</p>
5	<p>Taxes & Duties: All Taxes, Duties etc. as required to be paid in the country of export shall be included in the price quoted by the foreign vendor. All duties (like customs duty etc.) payable in India will be paid by BHEL (however, the same would be loaded to the offer during the evaluation process). For the supplies made from India taxes & duties payable shall be clearly mentioned in the offer, failing which such taxes and duties shall have to be borne by the vendor.</p> <p>Income Tax applicable. Any service charges payable towards supervision of E&C, training, performance prove-out etc., will be released after deduction of Income Tax as per Indian Income Tax Act / as per the Govt. of India rules and TDS certificate will be issued by BHEL for such deductions.</p> <p>Vendor's confirmation: We confirm that our offer has been made considering the above and we also confirm acceptance for deduction of Income tax as applicable.</p>
6	<p>Contract Execution Bank Guarantee: The successful vendor shall have to furnish a Contract Execution Bank Guarantee (CEBG) from any one of the 'Consortium Banks' of BHEL (list enclosed) for 5% of the Purchase Order value in the format enclosed covering the agreed delivery period (FOB delivery) with additional 2 months as claim period. The CEBG shall be furnished within 30 days from the date of Purchase Order. <u>BHEL reserves the right to cancel Purchase Orders in case the vendor fails to submit the CEBG within 30 days from Purchase Order date.</u> All bank charges incurred in India and outside India on account of issuance of CEBG will have to be borne by the foreign vendor. <u>Offers from vendors not accepting to submit CEBG will be rejected.</u></p> <p>Vendor's confirmation: CEBG will be provided in line with above.</p>
7	<p>Performance Bank Guarantee: The vendor shall submit a Performance Bank Guarantee (PBG) only from any one of the 'Consortium Banks' of BHEL (list enclosed) for 10% of the Purchase Order value in the format enclosed covering the agreed Guarantee period (with additional 2 months as claim period). All bank charges incurred in India and outside India on account of issuance of PBG will have to be borne by the foreign vendor. <u>Offers from vendors not accepting to submit PBG will be rejected.</u></p> <p>Vendor's confirmation: PBG will be provided in line with above.</p>
8	<p>Liquidated damages (LD): Delivery of the goods specified in the purchase order should be made within the time prescribed. Failure to dispatch the materials in the time as per the delivery indicated in our Purchase Order would make the supplier liable to an un-conditional penalty @ ½% of the value of goods for each week of delay subject to a maximum of 10% of the Purchase Order value.</p>

	For the purpose of Imposing LD, the FOB delivery (B/L date) shall be considered. BHEL reserves the right not to consider offers from vendors not accepting for the above LD clause, with maximum LD as 10%.
	Vendor's confirmation: We confirm acceptance to the above LD clause.
9	<p>Risk Purchase: If the supplier fails to deliver the goods within the delivery specified in the Purchase Order, BHEL will be entitled to terminate the contract and to purchase elsewhere at the risk and cost of the supplier either the whole of the goods or any part which the supplier has failed to deliver or dispatch within the delivery period mentioned in the Purchase Order. <u>BHEL reserves the right not to consider offers from vendors not accepting the above Risk Purchase terms.</u></p> <p>Vendor's confirmation: We confirm acceptance to the above Risk Purchase clause (without any modification).</p>
10	<p>Delivery terms, delivery period required and evaluation process: Delivery terms: Vendors should quote for delivery on CFR Chennai Sea Port / Air port as the case may be based on Incoterms 2000. However, price break-up details like FOB price, ocean freight/air freight etc., should be indicated in the offer. The transfer of title of the goods supplied by the vendor takes place in line with the Incoterms 2000. Delivery period: The equipment enquired forms a part of an expansion program (Scheme) and the delivery period of 10 months has been derived keeping in view of the Scheme completion date. Vendor shall have to confirm compliance for meeting the above delivery period. During evaluation of the offers, for vendors not confirming the requested delivery period, a grace period of 8 weeks (maximum) would be allowed. However, a loading @ ½% of the purchase order value per week will be done for the grace period requested. For evaluation 4 weeks will be considered as one month. Vendors are required to indicate the best delivery period i.e., time period required for dispatch (B/L or AWB date) from the date of Purchase Order in the "Vendor's confirmation" below. Order acceptance, submission of CEBG, drawings etc., should not be linked to the delivery period. <u>Vendors quoting a delivery period beyond the 'requested delivery plus the allowed grace period' will be rejected.</u></p> <p>Vendor's confirmation: We confirm our delivery shall be ___ months from the date of Purchase Order to date of B/L or AWB.</p>
11	<p>Guarantee: Vendors shall provide a guarantee for a period of 12 months from the date of commissioning of the equipment or 18 months from date of supply, whichever is earlier. The date of B/L or AWB shall be taken as the date of supply. Also, a PBG has to be given which shall cover the guarantee period (with additional 2 months as claim period). <u>Offers from vendors not accepting to the requested guarantee period will be rejected.</u></p> <p>Vendor's confirmation: We confirm to provide guarantee as requested above.</p>
12	<p>Reverse Auction (RA): BHEL reserves their right to conduct on-line internet Reverse Auction for finalizing the Tender. This decision will be communicated to the technically qualified vendors after technical evaluation. Details / General terms / guidelines for conduct of RA have been given in the 'General guidelines & instructions to bidders' enclosed as a part of NIT. Vendors are requested to confirm their acceptance for BHEL proceeding with RA route for finalization of the enquiry. <u>BHEL reserves the right not to consider offers from vendors not accepting to the RA process for finalization of the enquiry.</u></p> <p>Vendor's confirmation: We confirm participation in the RA process.</p>

13	Agency Commission: Vendors to specify the percentage agency commissioning payable to their Indian Agent in the vendor confirmation space below. If agency commission is not applicable, vendors to state the same clearly in the confirmation below.
	Vendor's confirmation:
14	Contacts: Details of contact person's name, designation, department with complete postal and email address along with phone and fax numbers to be mentioned
	Name: Designation: Email ID: Phone No.: Fax No.: Address:
15	Country of origin:
16	Port of loading:
17	Free Period for Container shipments: Vendors should indicate the mode of shipment Viz. break-bulk basis or container basis. Vendors should ensure that shipping lines carrying their cargo will allow a minimum free period of 14 days from the date of berthing of the vessel for clearing the consignment at the discharge port in case shipments are made using containers. Vendor's confirmation: We shall ensure the shipping lines allow a free period of minimum 14 days from the date of berthing of the vessel for clearing the consignment
18	Weight & Cubage of package: Approximate Net weight of the total consignment: Approximate Gross weight of the total consignment: Approximate volume of the total consignment:
19	The vendor to provide Business Information Report (BIR) incorporating the rating of the company by international credit rating agencies, viz., DUNS number of M/s DUN & Bradstreet (D&B) etc. Vendor's confirmation: We have enclosed BIR and our DUNS No. is:

We have gone through and understood the 'General guidelines & instructions to bidders for submitting offer' enclosed as a part of the NIT and confirm that our offer has been made in line with the same.

(AFFIX OFFICIAL SEAL HERE)

M/s

Signature with date:

Name:

Designation:

Department:

(PLEASE AFFIX YOUR SIGNATURE WITH SEAL ON EACH PAGE)

BHARAT HEAVY ELECTRICALS LIMITED TIRUCHIRAPALLI CAPITAL EQUIPMENT

Document No.MM/CE/CL/LC/IND/002A

ACCEPTANCE OF COMMERCIAL TERMS AND CONDITIONS BY THE VENDORS.

(This should be essentially filled in and sent along with the techno-commercial offer without fail. If this check list is not filled and submitted along with techno-commercial offer or if the vendor does not confirm acceptance to the terms and conditions proposed, BHEL reserves the right to reject such offer)

CHECK-LIST FOR INDIGENOUS VENDORS

Description of the Equipment:	CNC Horizontal Boring Machine – 900mm
BHEL Tender No. & Date:	2620900220 dated 07.10.2009

SI No	Description
1	<p>Price Bid: Price Bid should contain the schedule of price particulars and to be co-related to the technical details provided in Part I. Techno-commercial bid alone without the Price Bid will be rejected. The prices contracted shall be firm till the execution of the contract in full and in all respects.</p> <p>Vendor's confirmation: Accepted.</p>
2	<p>Validity: Validity of the offer should be 120 days from the date of tender opening. Please mention the validity period in the confirmation below. <u>BHEL reserves the right not to consider offers from vendors with validity less than 120 days from the date of tender opening.</u></p> <p>Vendor's confirmation:</p>
3	<p>Release of Purchase Order, submission of CEBG & PBG and terms of Payment:</p> <ul style="list-style-type: none"> ➤ Purchase Orders (separate for supply and service portion) will be released on the successful vendor. ➤ The successful vendor shall have to provide a Contract Execution Bank Guarantee (CEBG) only from any one of the 'Consortium Banks' of BHEL (list enclosed) for 5% of the Purchase Order value in the format enclosed within 30 days from the date of Purchase Order. <u>BHEL reserves the right to cancel Purchase Orders in case the vendor fails to submit the CEBG within 30 days from Purchase Order date.</u> ➤ The payment terms for the supply Purchase Order shall be 80% against receipt of the goods in BHEL and 20% after commissioning of the equipment in BHEL. ➤ An irrevocable unconfirmed domestic L/C will be opened for 24% of the supply Purchase Order value after receipt of CEBG. ➤ The above L/C would be enhanced to 80% of the supply Purchase Order value 2 months before the dispatch date. ➤ The above L/C can be negotiated after receipt of the equipment in BHEL against a certificate jointly signed by BHEL and the vendor (for safe receipt of the goods) and such other documents as mentioned in the Purchase Order. The above L/C will be valid for a period extending 21 days beyond the receipt (in BHEL) date for negotiation of documents. ➤ The balance 20% of the supply Purchase Order value plus 100% of the service Purchase Order value will be paid directly to the vendor after commissioning of the equipment in BHEL against commissioning certificate jointly signed by

	<p>BHEL and the vendor and submission of Performance Bank Guarantee (PBG) only from any one of the 'Consortium Banks' of BHEL (list enclosed) for 10% of the Purchase Order value in the format enclosed. This payment would be released within 30 days from the date of commissioning certificate jointly signed by BHEL and the vendor.</p> <p><u>Offers from vendors not accepting to receive at least 20% payment of the supply Purchase Order value after commissioning of the equipment will be rejected.</u></p>
	<p>Vendor's confirmation: Accepted to BHEL's above terms.</p>
4	<p>Taxes & Duties: All Taxes, Duties, Service Taxes etc. payable as extra to the quoted price should be specifically stated in offers along with CST & TIN No / Tariff No. etc., failing which BHEL will not be liable for payment of such Taxes and Duties. Our TIN No. 33243560005, TNGST No. 3560005, CST. No. 239383 Dt. 11-06-1991 & BHEL ECC No. AAACB4146PXM012, Assessment circle Tiruverambur In case taxes and duties are indicated as inclusive in the quoted prices, it will be reimbursed only upon furnishing the documentary evidence for having paid such taxes and duties. Any difference in taxes (on account of reduction in the levies) between what has been paid by BHEL to the vendor (based on what has been indicated in the Purchase Order) and actually paid by vendor should be passed on to BHEL.</p>
	<p>Vendor's confirmation: We confirm our offer has been made considering the above.</p>
5	<p>Contract Execution Bank Guarantee: The successful vendor shall have to furnish a Contract Execution Bank Guarantee (CEBG) from any one of the 'Consortium Banks' of BHEL (list enclosed) for 5% of the Purchase Order value in the format enclosed covering the agreed delivery period (FOR works delivery) with additional 2 months as claim period. The CEBG shall be furnished within 30 days from the date of Purchase Order. <u>BHEL reserves the right to cancel Purchase Orders in case the vendor fails to submit the CEBG within 30 days from Purchase Order date.</u> All bank charges incurred on account of issuance of CEBG will have to be borne by the vendor. <u>Offers from vendors not accepting to submit CEBG will be rejected.</u></p>
	<p>Vendor's confirmation: CEBG will be provided in line with above.</p>
6	<p>Performance Bank Guarantee: The vendor shall submit a Performance Bank Guarantee (PBG) only from any one of the 'Consortium Banks' of BHEL (list enclosed) for 10% of the Purchase Order value in the format enclosed covering the agreed Guarantee period (with additional 2 months as claim period). All bank charges incurred on account of issuance of PBG will have to be borne by the vendor. <u>Offers from vendors not accepting to submit PBG will be rejected.</u></p>
	<p>Vendor's confirmation: PBG will be provided in line with above.</p>

7	<p>Liquidated damages (LD): Delivery of the goods specified in the purchase order should be made within the time prescribed. Failure to dispatch the materials in the time as per the delivery indicated in our Purchase Order would make the vendor liable to an un-conditional penalty @ ½% of the value of goods for each week of delay subject to a maximum of 10% of the Purchase Order value. For the purpose of Imposing LD, the FOR Works delivery (LWB date) shall be considered. <u>BHEL reserves the right not to consider offers from vendors not accepting for the above LD clause, with maximum LD as 10%.</u></p>
	<p>Vendor's confirmation: We confirm acceptance to the above LD clause.</p>
8	<p>Risk Purchase: If the vendor fails to deliver the goods within the delivery specified in the Purchase Order, BHEL will be entitled to terminate the contract and to purchase elsewhere at the risk and cost of the supplier either the whole of the goods or any part which the supplier has failed to deliver or dispatch within the delivery period mentioned in the Purchase Order. <u>BHEL reserves the right not to consider offers from vendors not accepting the above Risk Purchase terms.</u></p>
	<p>Vendor's confirmation: We confirm acceptance to the above Risk Purchase clause (without any modification).</p>
9	<p>Delivery terms, delivery period required and evaluation process: Delivery terms: Vendors should quote for delivery on FOR BHEL, Tiruchy basis only. However, price break-up details like Ex-Works price, freight charges, insurance charges, taxes & duties etc., should be indicated in the offer. The transfer of title of the goods supplied by the vendor takes place only when the goods are delivered in good condition in BHEL, Tiruchy. Delivery period: The equipment enquired forms a part of an expansion program (Scheme) and the delivery period of 10 months has been derived keeping in view of the Scheme completion date. Vendor shall have to confirm compliance for meeting the above delivery period. During evaluation of the offers, for vendors not confirming the requested delivery period, a grace period of 8 weeks (maximum) would be allowed. However, a loading @ ½% of the purchase order value per week will be done for the grace period requested. For evaluation 4 weeks will be considered as one month. Vendors are required to indicate the best delivery period i.e., time period required for dispatch (LWB date) from the date of Purchase Order in the "Vendor's confirmation" below. Order acceptance, submission of CEBG, drawings etc., should not be linked to the delivery period. <u>Vendors quoting a delivery period beyond the 'requested delivery plus the allowed grace period' will be rejected.</u></p>
	<p>Vendor's confirmation: We confirm our delivery shall be __ months from the date of Purchase Order to date of LWB.</p>
10	<p>Guarantee: Vendors shall provide a guarantee for a period of 12 months from the date of commissioning of the equipment or 18 months from date of supply, whichever is earlier. The date of LWB shall be taken as the date of supply. Also, a PBG has to be given which shall cover the guarantee period (with additional 2 months as claim period). <u>Offers from vendors not accepting to the requested guarantee period will be rejected.</u></p>

	Vendor's confirmation: We confirm to provide guarantee as requested above.
11	Reverse Auction (RA): BHEL reserves their right to conduct on-line internet Reverse Auction for finalizing the Tender. This decision will be communicated to the technically qualified vendors after technical evaluation. Details / General terms / guidelines for conduct of RA have been given in the 'General guidelines & instructions to bidders' enclosed as a part of NIT. Vendors are requested to confirm their acceptance for BHEL proceeding with RA route for finalization of the enquiry. <u>BHEL reserves the right not to consider offers from vendors not accepting to the RA process for finalization of the enquiry.</u>
	Vendor's confirmation: We confirm participation in the RA process.
12	Contacts: Details of contact person's name, designation, department with complete postal and email address along with phone and fax numbers to be mentioned
	Name: Designation: Email ID: Phone No.: Fax No.: Address:
13	Weight & Cubage of package: Approximate Net weight of the total consignment: Approximate Gross weight of the total consignment: Approximate volume of the total consignment:
14	The vendor to provide Business Information Report (BIR) incorporating the rating of the company by international credit rating agencies, viz., DUNS number of M/s DUN & Bradstreet (D&B) etc. Vendor's confirmation: We have enclosed BIR and our DUNS No. is:

We have gone through and understood the 'General guidelines & instructions to bidders for submitting offer' enclosed as a part of the NIT and confirm that our offer has been made in line with the same.

(AFFIX OFFICIAL SEAL HERE)

M/s

Signature with date:

Name:

Designation:

Department:

(PLEASE AFFIX YOUR SIGNATURE WITH SEAL ON EACH PAGE)